

CAPRARI

TRACTOR DRIVEN & ENGINE MOUNTED CENTRIFUGAL PUMPS

SINCE 1952

50

YEARS OF
EXCELLENCE

Cadman
POWER EQUIPMENT
Limited

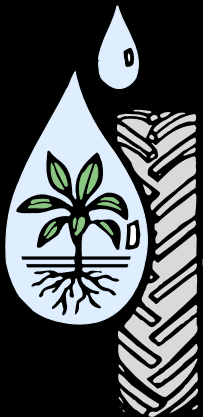

THE CADMAN-CAPRARI PUMP DIFFERENCE
strength... simplicity... dependability

SINGLE STAGE TRACTOR DRIVEN PUMPS



Caprari pumps are known world-wide for their quality construction, reliability, and high efficiency. For these reasons Cadman has teamed up with Caprari to provide you with these high quality products. Cadman has seven different single stage models to offer, from 50 GPM to 1300 GPM. These pumps are available in bare and fitted forms. Bare pumps are supplied with counterflanges, gaskets and bolts. Fitted pumps come complete with a heavy duty two wheel cart, PTO shaft, liquid pressure gauge, priming check valve, hand primer and NPT thread for the suction port.

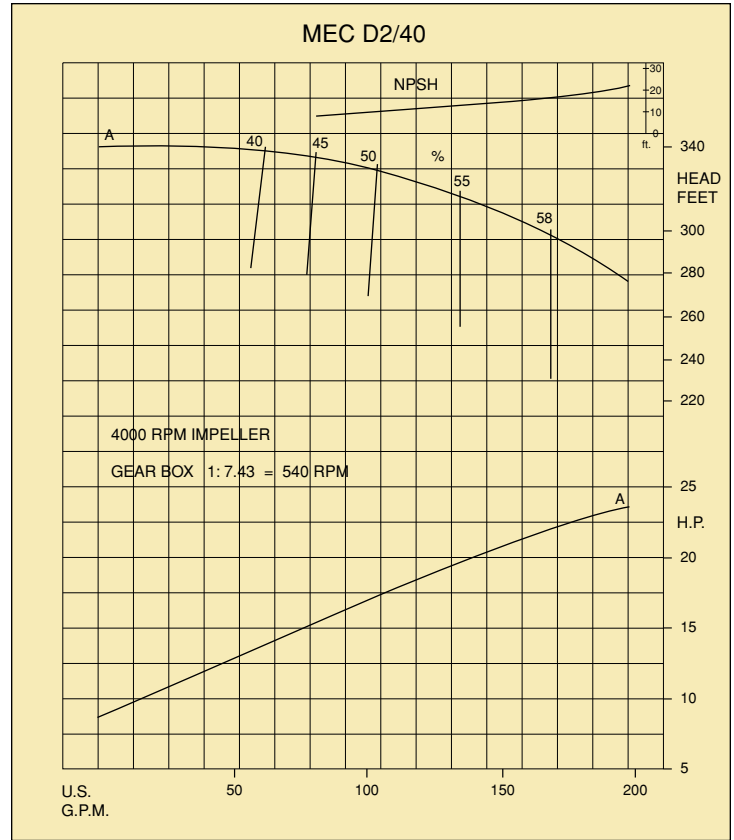

All pumps come with the discharge port facing horizontal left (when standing behind suction side). Upon request, they can be rotated to vertical or horizontal right.

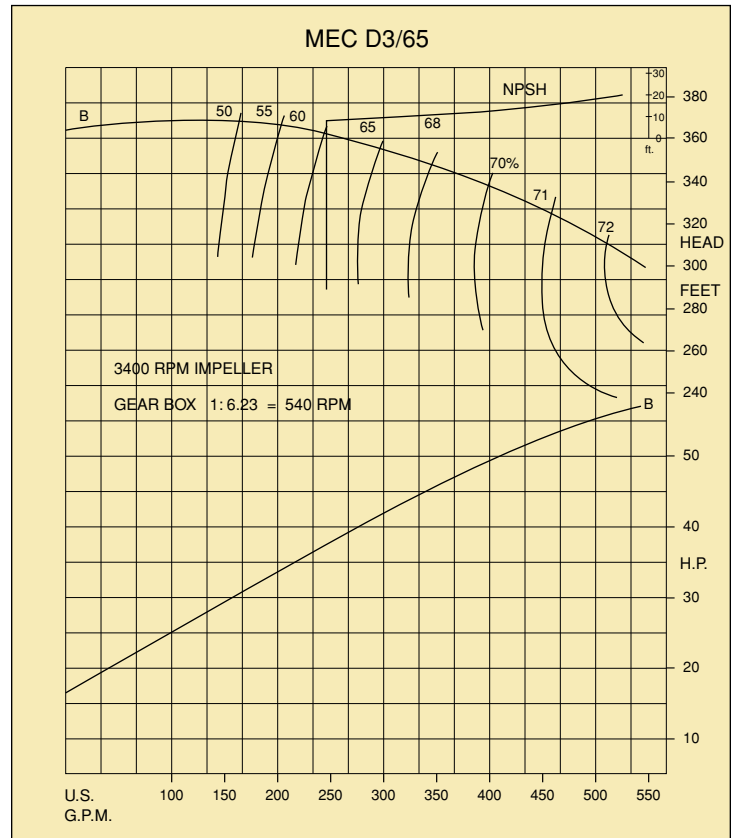
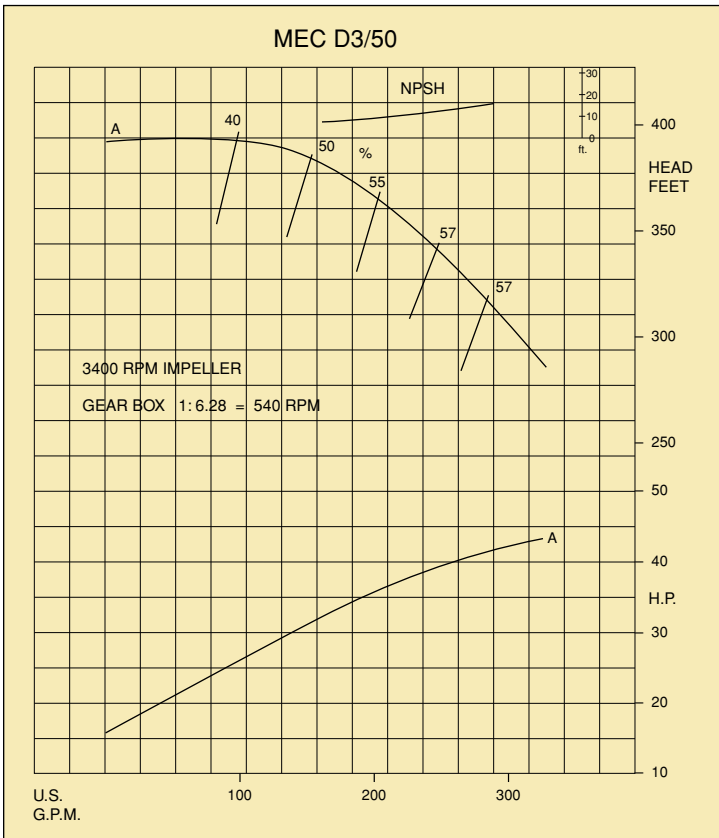

SINGLE STAGE TRACTOR DRIVEN PUMPS

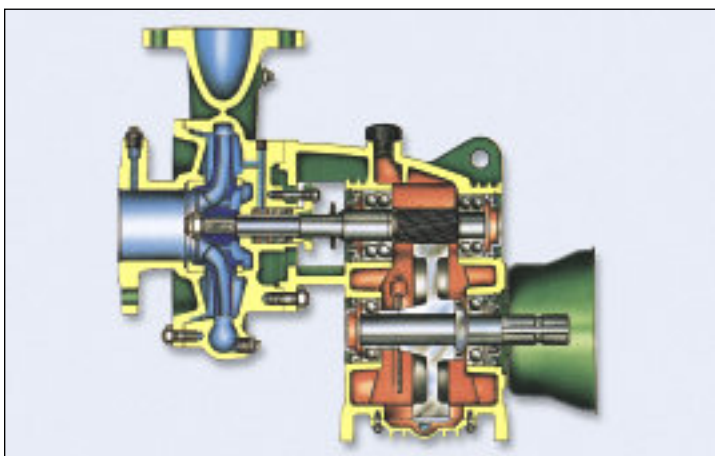
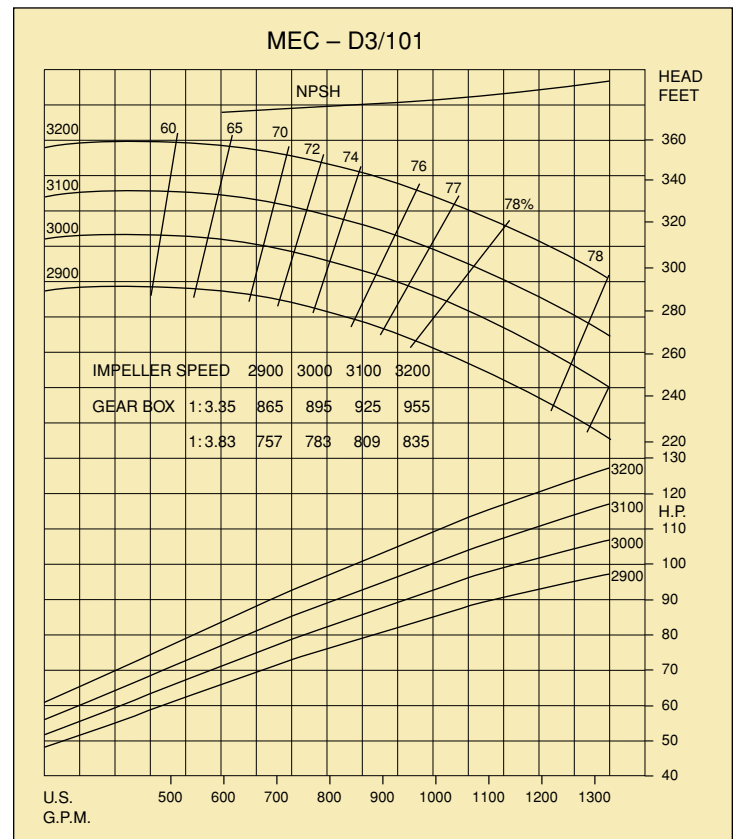
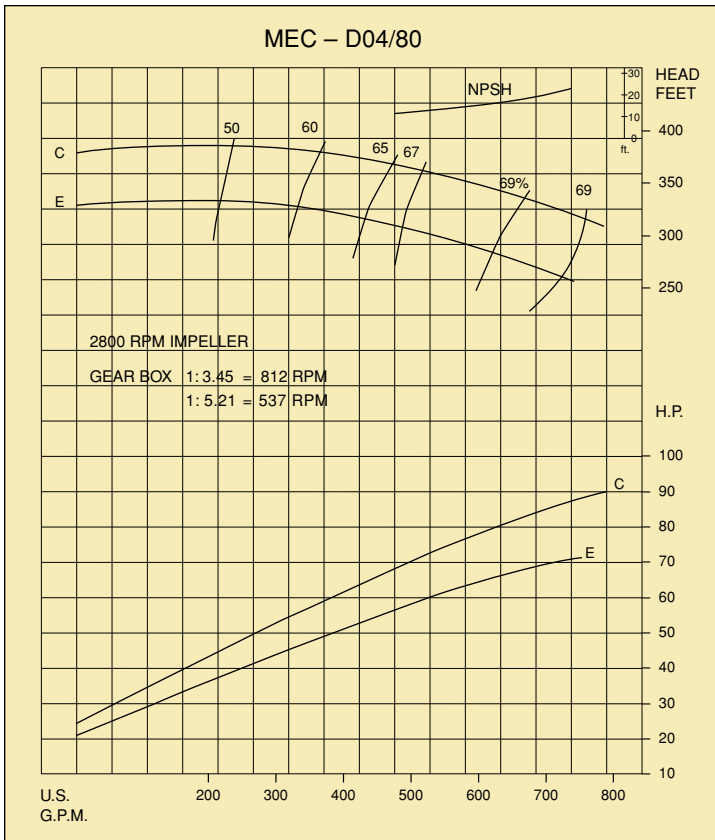

Single and two-stage pumps are constructed from close grained cast iron. The balanced impellers have two replaceable wear rings for each impeller. A heavy duty step-up gear box has hardened helical spur gears running in oil. Unlike other pump companies that use chromed steel for their pump shafts, Caprari only uses high grade stainless steel. The two shafts are supported by high quality bearings. A simple stuffing box seal is incorporated with a replaceable chromed steel shaft bushing.

MULTIPLE STAGE TRACTOR DRIVEN PUMPS



For overall efficiency, nothing compares to Caprari's line of multiple-stage PTO pumps. With five different models to choose from Cadman can fine tune the perfect pump for you. Multiple gear box ratios and the ability to trim impellers makes this possible. For those rough, hot summer days, Caprari has incorporated a cooling coil constructed from stainless steel.



As an option, all Caprari pumps can have a 12 volt power primer installed. (Also available as a portable unit).

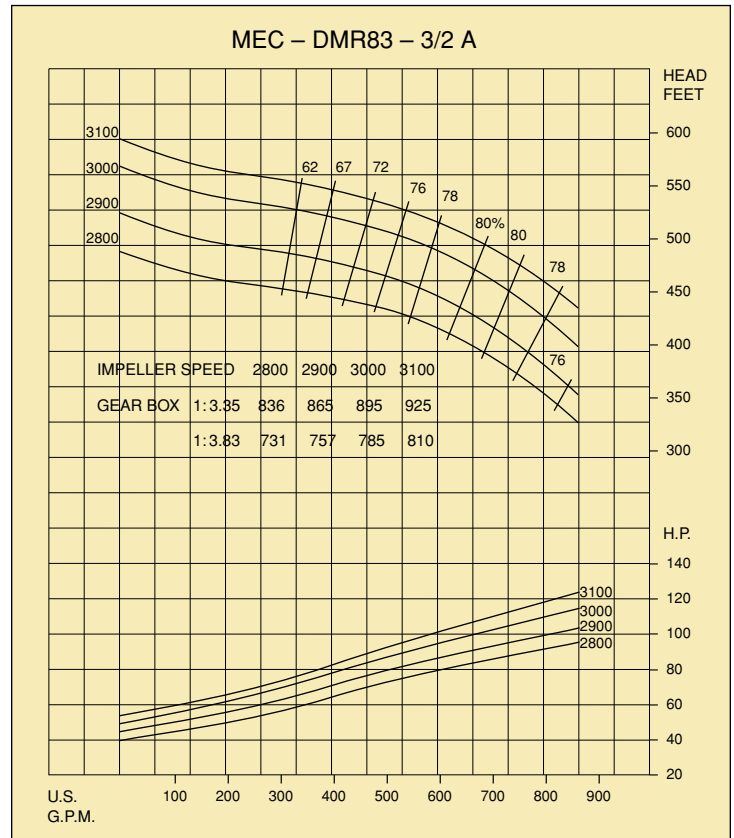
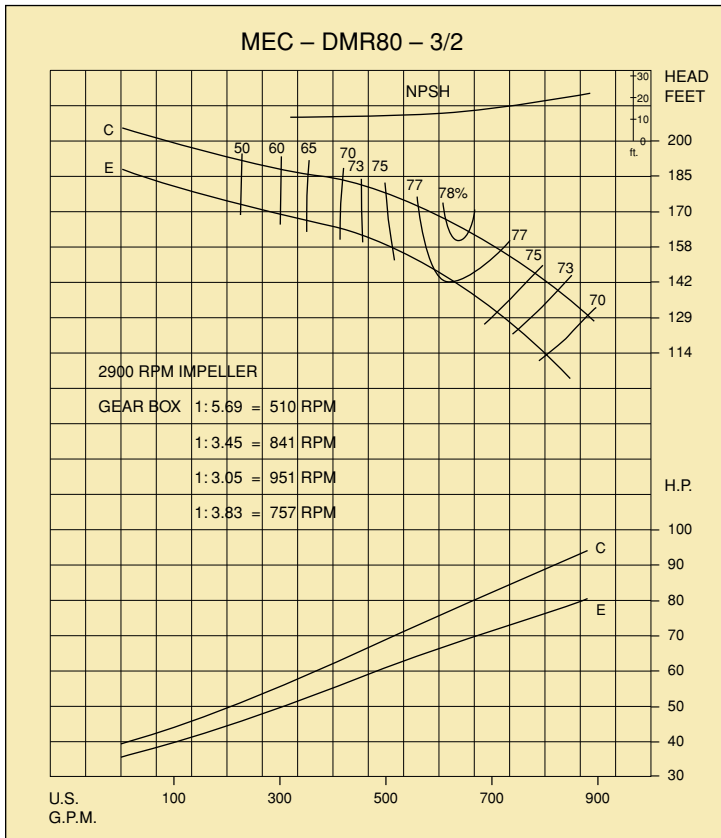

MULTIPLE STAGE ENGINE MOUNTED PUMPS

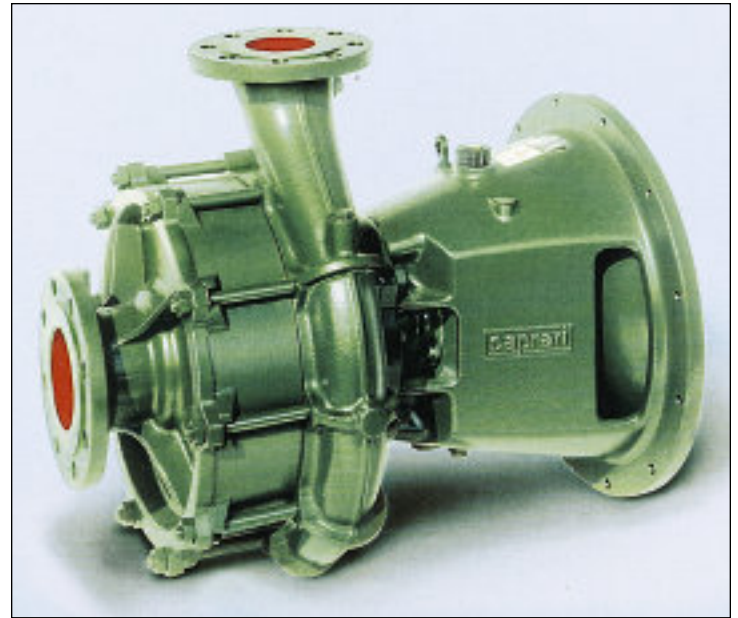
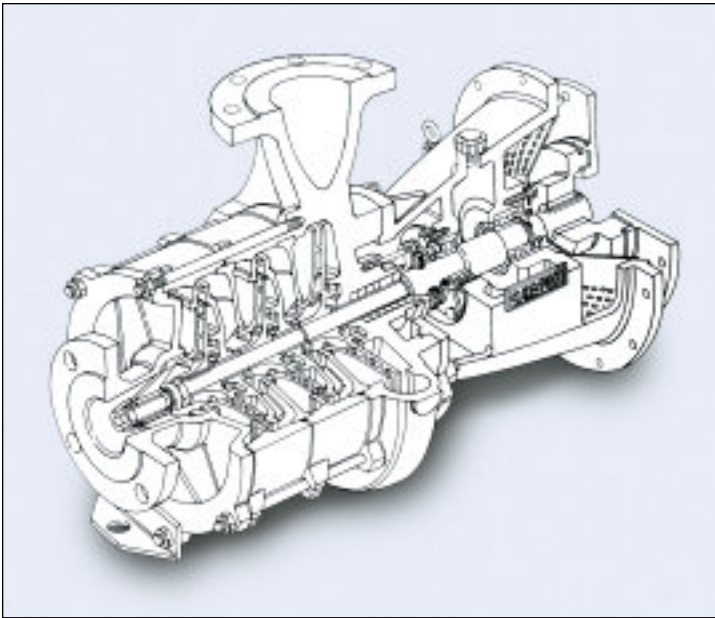

The two and three-stage horizontal shaft centrifugal pumps are equipped with oversized supports and bearings to provide superior coupling dependability for connection to a gasoline or diesel engine.

All pumps are flanged for SAE 3 engines, however, adapter rings are available for SAE 1, 2 and 4 engines. Pumps are composed of a suction cover, flow directing bladed diffusers, volute shaped casing, bearing housing, grey cast iron impellers, stainless steel shaft and external carbon steel tie bolts to securely fasten the pump assembly.

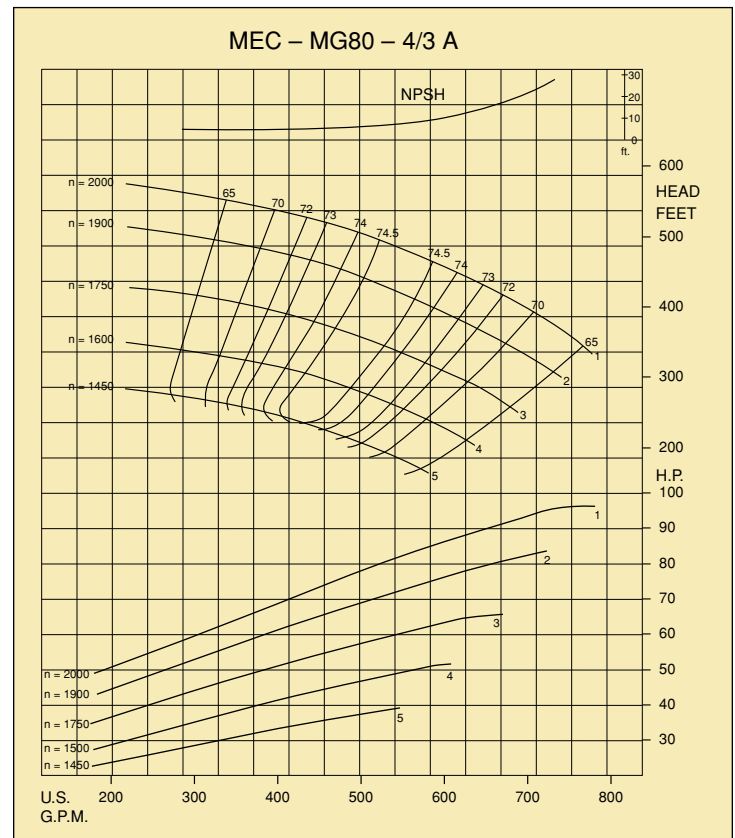
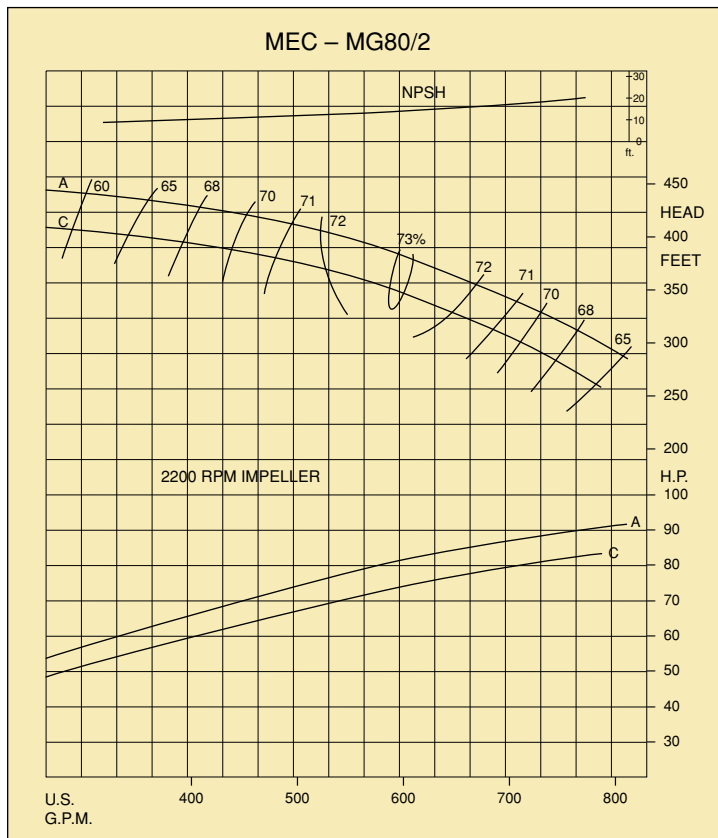

MULTIPLE STAGE ENGINE MOUNTED PUMPS

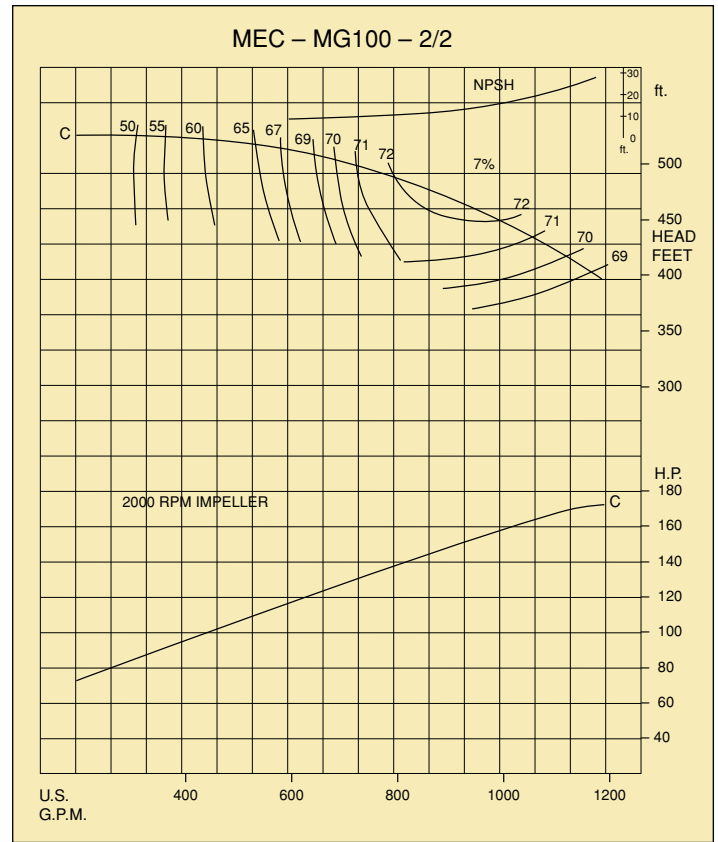
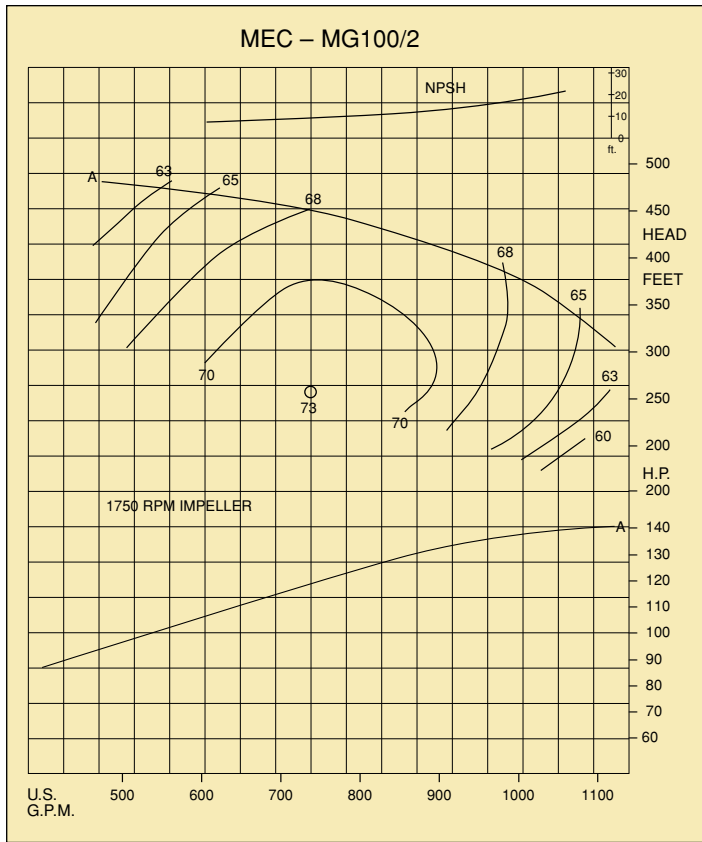

Two replaceable wear rings are provided for each impeller. The shaft is supported by two oil lubricated roller bearings. Three-stage pumps incorporate an additional support for the shaft in the form of a bronze journal bearing located in the suction cover, equipped with a mounting bracket. The pump shaft is protected by a replaceable, chromed steel sleeve which is situated in the packing gland area.

See your irrigation representative about Cadman's complete line of irrigation products.



Cadman Travellers



Power Units



Manure Pumps



Aluminum Pipe and Fittings



PVC Pipe and Fittings

Cadman Power Equipment Limited, whose policy is one of continuous improvement, reserves the right to change specifications, design or prices without incurring obligation.

Cadman
POWER EQUIPMENT
Limited

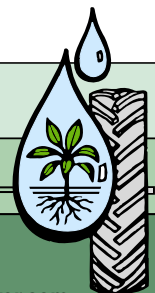

AGRICULTURAL MACHINERY AND IRRIGATION EQUIPMENT

Box 100, Courtland, Ontario, Canada N0J 1E0

Phone (519) 688-2222 • Fax (519) 688-2100

E-mail: inquiries@cadmanpower.com www.cadmanpower.com